



Subaru Legacy/Outback (with NAV) 2010-2012

Visit MetraOnline.com for more detailed information about the product and up-to-date vehicle specific applications

KIT FEATURES

- ISO DDIN radio provision
- Painted silver to match the factory finish
- Includes a pocket to replace the factory radio controls

KIT COMPONENTS

- A) Radio trim panel • B) Radio brackets • C) Pocket • D) (4) #8 x 3/8" Phillips screws • E) (4) Panel clips

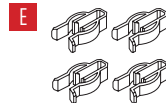
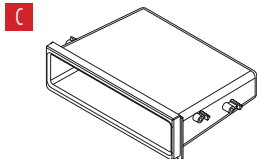
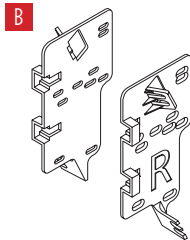
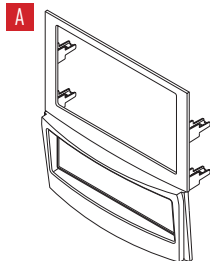

TABLE OF CONTENTS

Dash Disassembly	2
Kit Assembly	3

WIRING & ANTENNA CONNECTIONS (sold separately)

Wiring Harness: 70-7553[†]

Antenna Adapter: 40-SB10-18

[†] Reference note in Kit Assembly

TOOLS REQUIRED

- Panel removal tool • Phillips screwdriver

Attention! Let the vehicle sit with the key out of the ignition for a few minutes before removing the factory radio. When testing the aftermarket equipment, ensure that all factory equipment is connected before cycling the key to ignition.

DASH DISASSEMBLY

1. Unclip and remove the a/c vent trim panel surrounding the radio. (Figure A)
2. Remove (6) Phillips screws securing the radio/display. Slide the radio/display out, then unplug and remove the radio/display.

Note: The antenna cable is connected down lower by the floorboard.

3. Cut and remove the shaded area shown in the sub-dash to make clearance for the aftermarket radio. (Figure B)

Continue to Kit Assembly

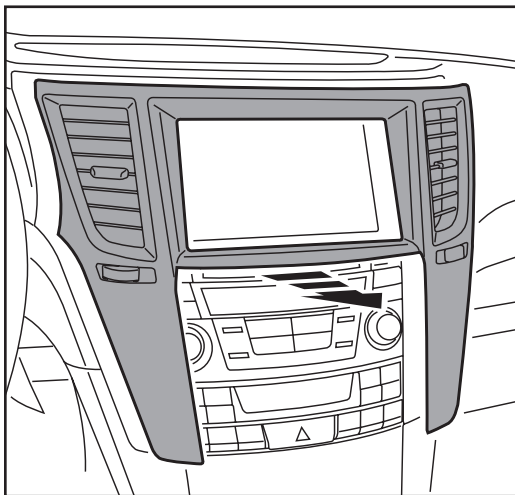

(Figure A)

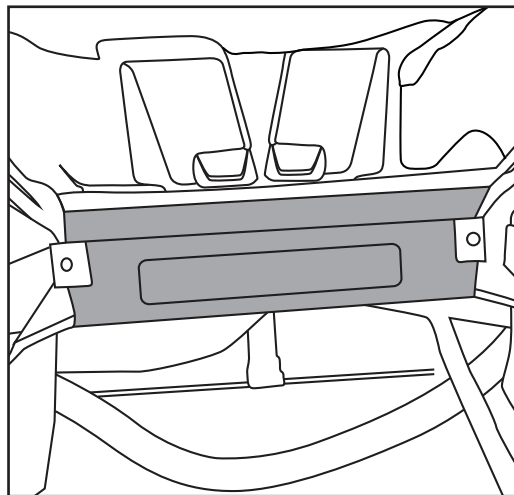

(Figure B)

KIT ASSEMBLY

1. Secure the *radio brackets* to the radio using the screws supplied with the radio. (Figure A)
2. Secure the *pocket* to the bottom portion of the *radio brackets* using the (4) #8 x 3/8" Phillips screws provided. (Figure B)
3. Locate the factory wiring harness and antenna connector in the dash and complete all necessary connections to the radio. Metra recommends using the proper mating adapter from Metra and/or Axxess. Test the radio for proper operation.

Note: The amplifier turn-on wire must be tapped into the factory radio harness. Locate pin-23, a **Pink** wire, in the 24-pin harness.

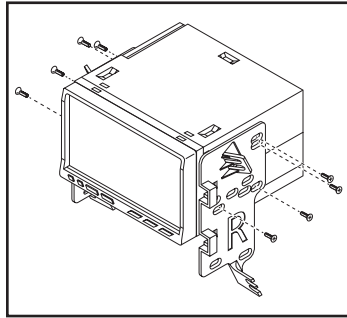

(Figure A)

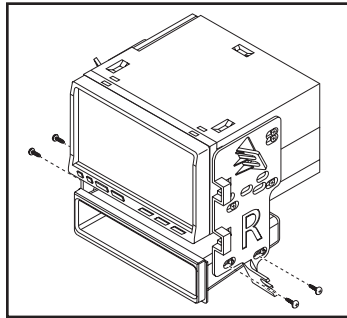

(Figure B)

4. Secure the radio assembly to the dash using the factory screws.
5. Attach the (4) *panel clips* provided onto the *radio trim panel*, then clip the *radio trim panel* onto the radio assembly. (Figure C)
6. Reassemble the dash in reverse order of disassembly to complete the installation.

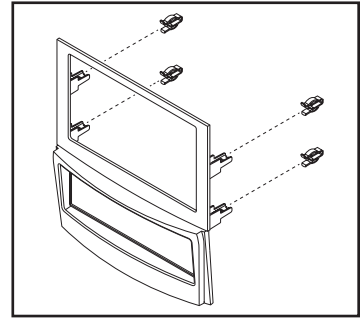

(Figure C)



95-8910S
INSTALLATION INSTRUCTIONS



If you are having difficulties with the installation of this product, contact our Tech Support line either by phone at **386-257-1187**, or email at **techsupport@metra-autosound.com**. Before doing so, look over the instruction booklet a second time and ensure that the installation was performed exactly as the instruction booklet is stated. Have the vehicle apart and ready to perform troubleshooting steps before contacting Metra/Axxess Tech Support.



KNOWLEDGE IS POWER

Enhance your installation and fabrication skills by enrolling in the most recognized and respected mobile electronics school in our industry. Log onto www.installerinstitute.com or call 800-354-6782 for more information and take steps toward a better tomorrow.



Metra recommends MECP certified technicians