

BIG ENERGY RAW 9" / LENS COVERS DRIVING LIGHT

WIRING INSTRUCTIONS

- RED: + XPERIENCE MODE
- BLACK: - NEGATIVE
- GREEN: + E-MODE *

TYPE OF CONNECTION: DT-2 connector (One loose cable)

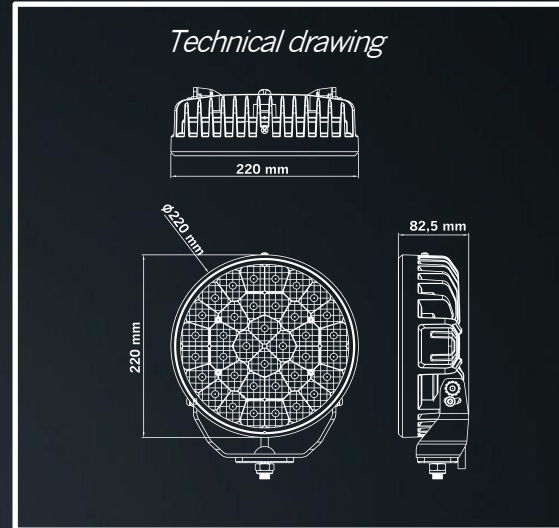

ADDITIONAL INFORMATION

***Cable connection for E-mode and Xperience mode:**

Green Cable: Activates E-Mode.

Red Cable (DT2): Activates Xperience Mode.

Priority for both mode:

When both green and red cables are connected to the battery's positive pole, E-Mode takes priority over Xperience Mode. Xperience Mode will not be activated.

Mode Switching:

To activate Xperience Mode, the E-Mode connection must be powered off. This can be achieved by using an external switch to disconnect the E-Mode signal or by interrupting the power supply to the E-Mode system. Ensure the wiring is properly configured to allow for this switching between modes.

*If you don't need E-mode then do not required to connect green cable

TECHNICAL DRAWING 901036-37 LENS COVER

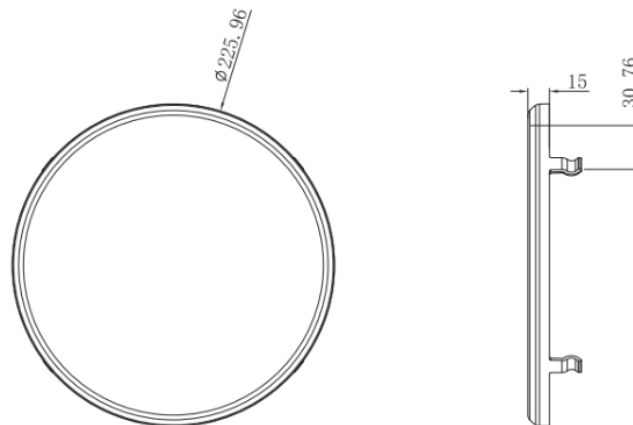

CONNECTION DIAGRAM

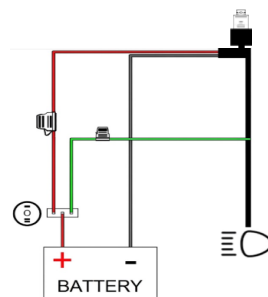

INCLUDED IN PACKAGE:

- Bracket
- Screws: 1 pcs M12 , 2 pcs M8, 2 pcs M6
- Nuts: 1 pcs M12
- Washers: 2x M8 Screw, 2x M8 Spacer, 2x M8 Spring Washer, 2x M8 Nylon Spacer, 2x M6 Screw, 2x M6 Spacer, 2x M6 Nylon Spacer
- Pig tail: DT-2
- Rubber pad: Yes
- Top stabilizer hole: M4
- Cable specification: Red/Black: 1.5mm² , Green: 0.5mm²
- Lens covers (901036 Clear Flood and 901037 Yellow Flood) are sold separately.

READ ALL THE INSTRUCTIONS AND STUDY THE DIAGRAMS BEFORE INSTALLING NEW LIGHT!

LEGAL MOUNTING

- Please check state and local laws for proper usage and mounting. Strands will not be responsible for products mounted incorrectly or in violation of local laws (e.g., ECE R48 regulation for the EU)

PRODUCT CARE

- Clean the product with lukewarm water and an alkaline degreaser. Avoid strong chemicals; rinse immediately if exposed. Do not use a pressure washer for cleaning.
- Take care if your light has a breather. Ensure it is protected against rain and dust, especially if it has a sticker breather. Damage to the breather due to incorrect installation will void the warranty.
- Internal moisture is normal and will dissipate through the breather vent after several days of use.
- We do not recommend painting the product housing. If paint is still applied, please ensure the breather is protected and an oven is not used for curing the paint. Otherwise, the warranty might be void.

INSTALLATION

- Ensure power is turned off during installation.
- Do not cut the connector cable to less than 50 cm. If the original cable is already shorter than 50 cm, leave it as is. Otherwise, the warranty will be void.
- Make sure to use only the correct accessories included in the package. Installation errors may void the warranty.
- Tighten screws, washers, and nuts to prevent them from loosening or chafing. Do not overtighten screws to avoid damaging the product's protective components.
- Use a watertight solution for wiring connections.

WARNING!

- For safe operation, use only the voltage specified in the product description. This light becomes hot under continuous use. Do not remove or touch the casing for at least 30 minutes after turning the lamp off



Contact us if you need support: support@strands.se or +46(0)320-450450
Please also refer to the FAQ section on our website for more information.

www.strandseurope.com



strands[®]
-lighting division